

SPS2

DIFFERENTIAL PRESSURE
CONTROLLER WITH TWO
SETPOINTS

Mounting and operating instructions



Table of contents

SAFETY AND PRECAUTIONS	3
PRODUCT DESCRIPTION	4
ARTICLE CODES	4
INTENDED AREA OF USE	4
TECHNICAL DATA	4
STANDARDS	5
OPERATIONAL DIAGRAM	5
WIRING AND CONNECTIONS	6
MOUNTING INSTRUCTIONS IN STEPS	6
OPERATING INSTRUCTIONS	9
VERIFICATION OF THE INSTALLATION INSTRUCTIONS	12
TRANSPORT AND STORAGE	13
WARRANTY AND RESTRICTIONS	13
MAINTENANCE	13

SAFETY AND PRECAUTIONS



Read all the information, the datasheet, Modbus Register map, mounting and operating instructions and study the wiring and connection diagram before using the product. For personal and equipment safety, and for optimum product performance, make sure you entirely understand the content before installing, using or maintaining this product.



Unauthorised conversion and/or modification of the product is not permitted for safety and licensing (CE) reasons.



The product should not be exposed to abnormal conditions, such as extreme temperatures, direct sunlight or vibrations. Long-term exposure to chemical vapours in high concentration can affect the product performance. Make sure the work environment is as dry as possible and avoid condensation.



All installations shall comply with local health and safety regulations, local electrical standards and approved codes. This product can only be installed by an engineer or a technician who has expert knowledge of the product and of the safety precautions.



Avoid contact with energised electrical parts. Always disconnect the power supply before connecting, servicing or repairing the product.



Always ensure that the product is powered properly and that the wire size and characteristics are appropriate. Make sure that all the screws and nuts are well tightened and fuses (if any) are fitted well.



Recycling of equipment and packaging should be taken into consideration and these should be disposed of in accordance with local and national legislation / regulations.



If you have any further questions, please contact your technical support or consult a professional.

PRODUCT DESCRIPTION

The SPS2 differential pressure controller directly controls EC fans, frequency inverters or other control units with two differential pressure setpoints (high/low or day/night mode option). It provides an analogue or digital output with integrated PI control and K-factor setting. You can switch between the setpoints by means of an external switch / contact or digitally. All system parameters are controllable via Modbus RTU communication.

ARTICLE CODES

			Article codes
	Supply	Adjustable ranges [Pa]	Connections
SPS2G-2K0	13–26 VAC	Automatically switched according to the current setpoint	3-wire
SPS2G-6K0	18–34 VDC		
SPS2F-2K0	18–34 VDC		4-wire
SPS2F-6K0			

INTENDED AREA OF USE

- Direct fan / pressure control for EC drives and frequency inverters, VAV (Variable Air Volume) and CAV* (Constant Air Volume) mode.
 - Valve and damper control (actuators)
 - Direct pressure / airflow equipped in clean rooms equipped with EC drives and frequency inverters
- * Only when K-factor of the fan is known (consult the datasheets)*

TECHNICAL DATA

- Long-term stability and accuracy
- 1 analogue / digital output PWM (open collector)
- Modbus RTU (RS485) communication
- Integrated PI control, K-factor and setpoint adjustment
- Switching between 2 setpoints (via external switch / contact or digital output / Modbus)
- Automatic range selection according to the selected setpoint
- Selection of differential pressure or air volume mode / readout via Modbus
- Modbus register reset function (factory preset values)
- Sensor calibration procedure
- Autotune function
- Aluminium pressure connection nozzles
- Operating ambient conditions:
 - ▶ Temperature: -5–65 °C
 - ▶ Rel. humidity: < 95 % rH (non-condensing)
- Storage temperature: -20–70 °C

STANDARDS

- EMC Directive 2014/30/EC:
- Low Voltage Directive 2014/35/EC
- WEEE Directive 2012/19/EU,
- RoHs Directive 2011/65/EC



OPERATIONAL DIAGRAM

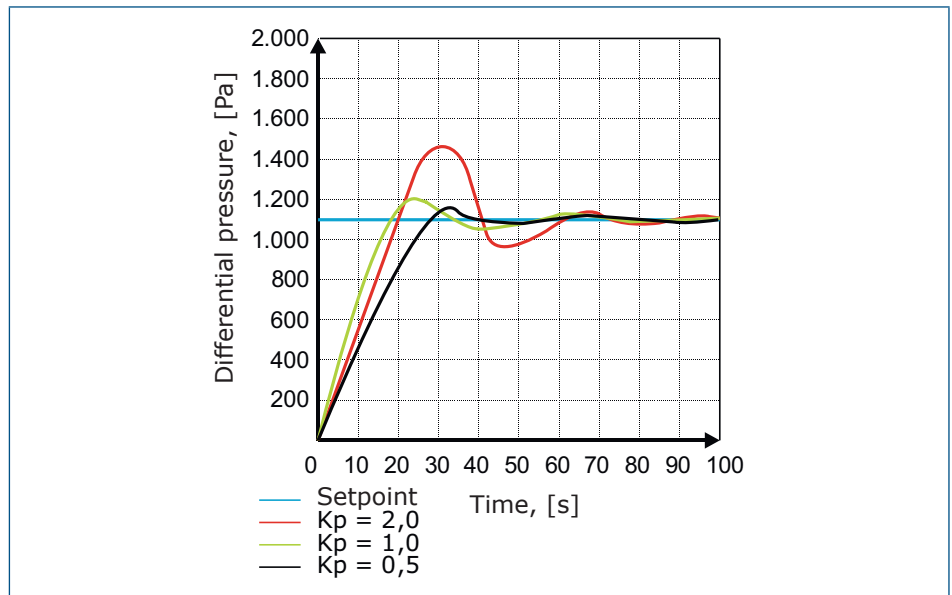

NOTE

The minimum output value can be adjusted in the range between 10 to 50 %. A minimum amount of air flow is required to control a fan in a stable way. When the operation mode is 'stop', the fan is stopped and there is no pressure in the control application.

WIRING AND CONNECTIONS

Wiring and connections	
Vin	Positive DC voltage / AC ~
GND	Ground / AC ~
A	Modbus RTU (RS485) signal A
/B	Modbus RTU (RS485) signal /B
AO1	Analogue / digital output PWM (open collector)
GND	Ground
OC	Dry contact for switching between setpoint 1 and 2
GND	Ground
Connections	Cable cross section: max. 0,75 / 1,5 mm ² Cable gland clamping range: 3–6 mm

ATTENTION

The -F version of this product is not appropriate for 3-wire connections. Power supply and analogue output have separate grounds. Making the connection between the two grounds could lead to inaccurate measurements. Connecting -F type sensors requires a minimum of 4 wires.

The -G version has a "common ground" and is designed for 3-wire connections. This indicates that the grounds of the power supply and the analogue output are internally connected. This makes it impossible to use the -G and -F types simultaneously on the same network. Never connect a device powered by a DC voltage to the common ground of a product of the -G type. This could harm the connected devices permanently.

MOUNTING INSTRUCTIONS IN STEPS

Before you start mounting the unit, read carefully **“Safety and Precautions”**. Choose a smooth surface for installation (a wall, panel, etc.) and follow these steps:

1. Unscrew the front cover of the enclosure to remove it.
2. Fix the enclosure onto the surface by means of suitable fasteners while adhering to the mounting dimensions shown in **Fig. 1** and the correct mounting position shown in **Fig. 2** below.

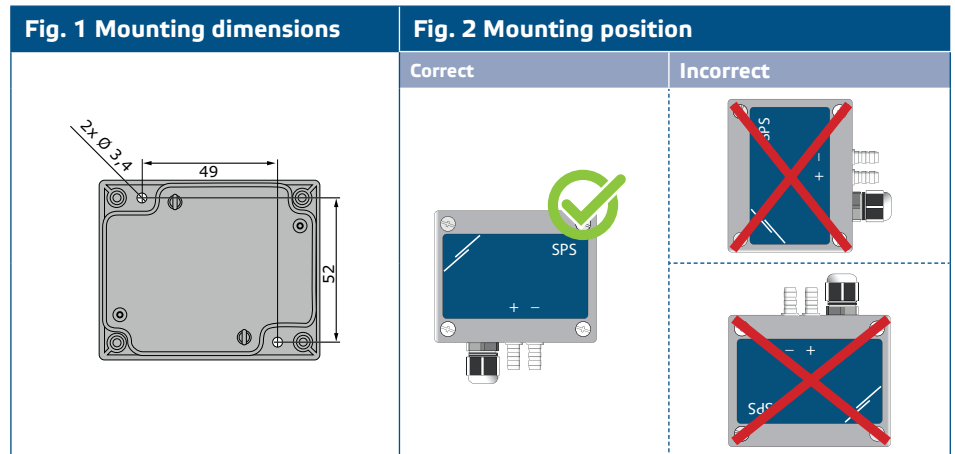

3. Insert the cable into the cable gland.
4. Connect as shown in **Fig. 3** adhering to the information in section **“Wiring and connections”**.

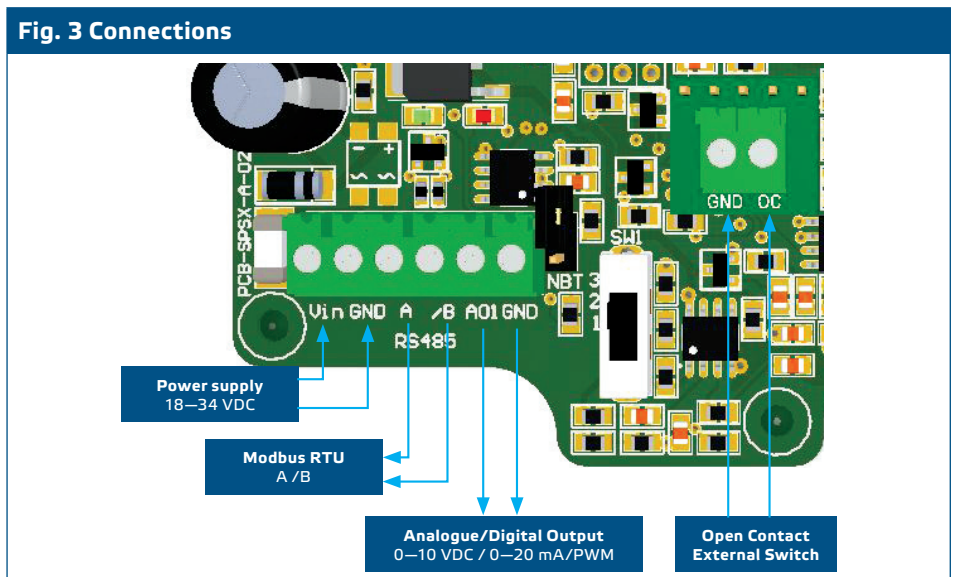

5. Connect the nozzles to the duct (see **Fig. 4**). Depending on the application you must use a specific connection set to connect the nozzles of the unit to the duct:
 - 5.1 To control differential pressure, use PSET-QF or PSET-PVC set (pressure measurement is the unit default setting);
 - 5.2 To control volume flow, use PSET-PT Pitot tube connection set, PSET-QF or PSET-PVC connection set.

Fig. 4 Connecting with accessories

Application 1: Controlling differential pressure [Pa] or volume flow [m³/h] using PSET-PVC

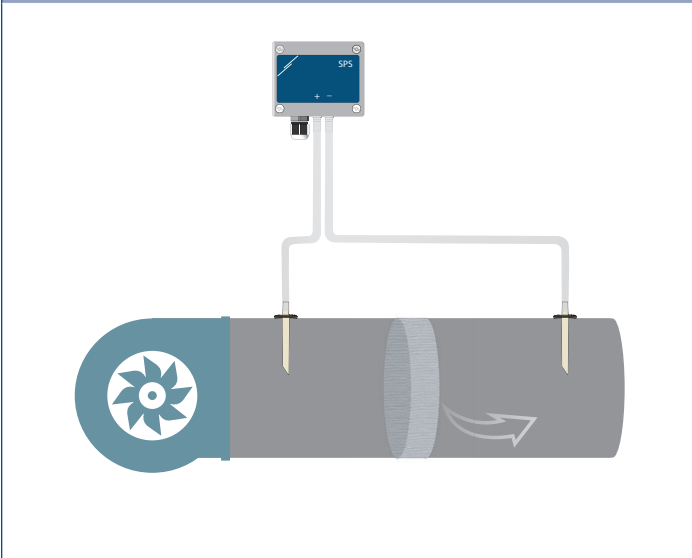

Application 2: Controlling volume flow [m³/h] or air velocity [m/s] using PSET-PT

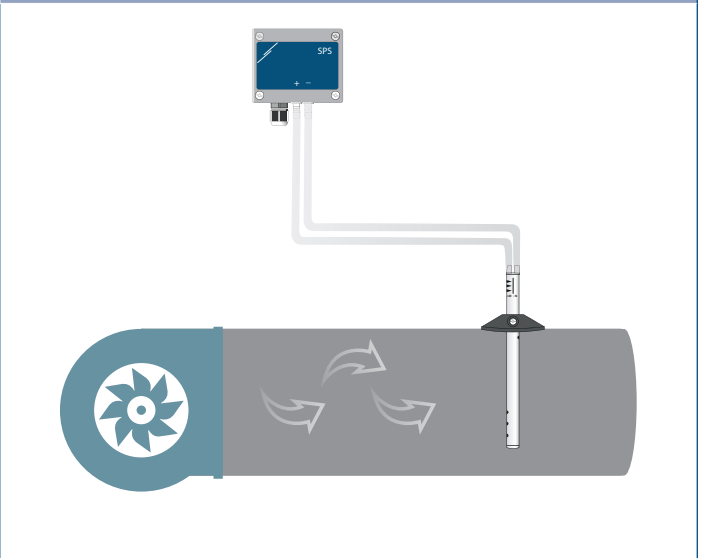

6. Switch on the power supply.

NOTE

For sensor calibration and Modbus registers reset procedures, refer to section "Operating instructions". Always calibrate the sensor before initial use.

PWM (Open Collector) connection example:

- When SW1 is in position 3, the output type is Open collector. See Fig. 6. An external pull-up resistor must be used when the analogue output (AO1) is assigned as PWM output.

Fig. 6 PWM (Open collector) connection

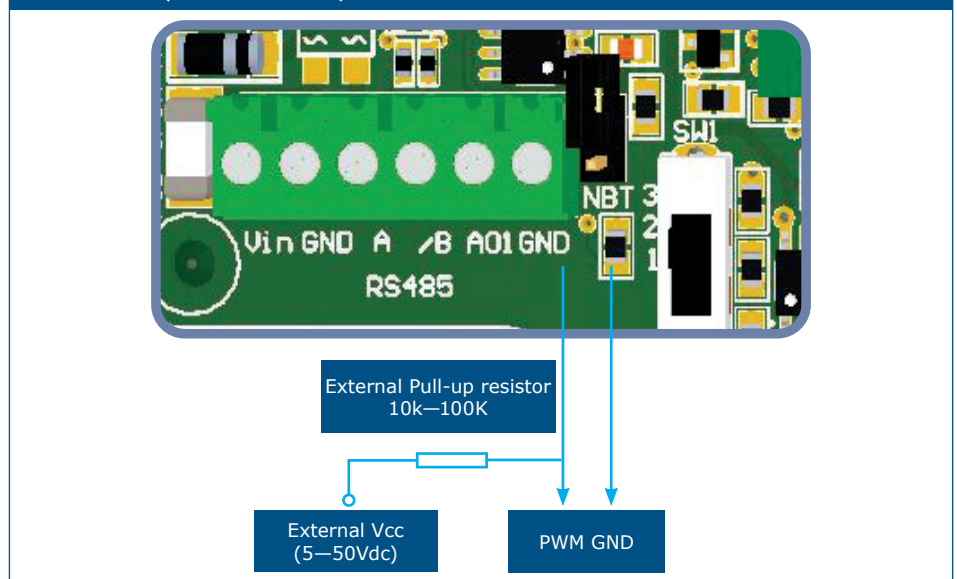

Optional settings

To assure correct communication, the NBT needs to be activated in only two devices on the Modbus RTU network.

Fig. 7 Network bus resistor jumper

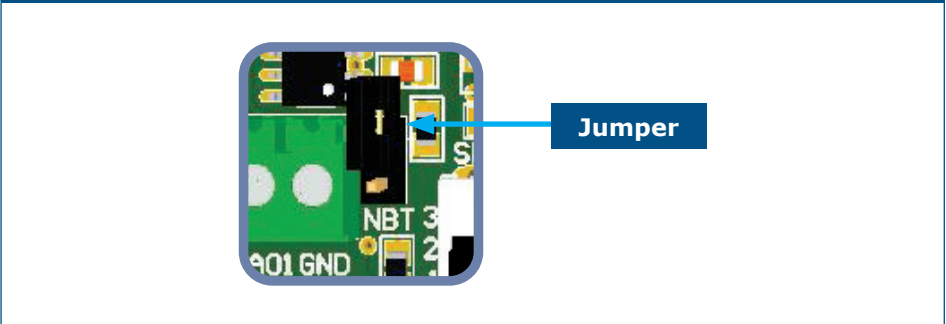

Example 1

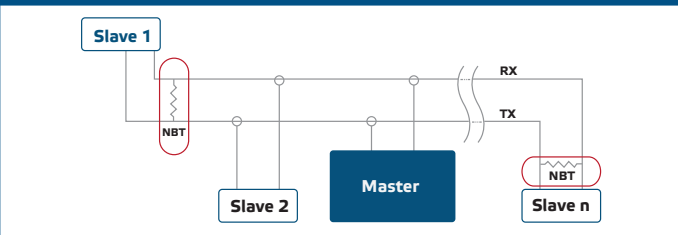

Example 2

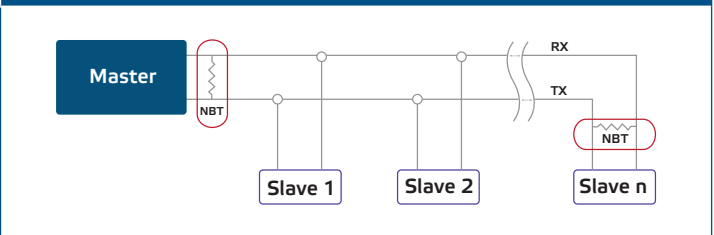

NOTE

On a Modbus RTU network, two bus terminators (NBTs) need to be activated.

7. Put back the front cover and secure it with the screws.
8. Customise the factory settings to the desired ones via the 3SModbus software. For the default factory settings, see *Modbus register map*.

NOTE

For the complete Modbus register data, refer to the product *Modbus Register Map*, which is a separate document attached to the article code on the website and contains the registers list. Products with earlier firmware versions may not be compatible with this list.

OPERATING INSTRUCTIONS

NOTE

For detailed information and settings, refer to the product *Modbus register map*, which is attached to the article code on our website.

Calibration procedure:

1. Disconnect the nozzles and make sure they are not clogged and the tubing set is not connected.
2. Press button SW2 and hold for 4 seconds until blue LED on the printed circuit board blinks two times, then release the button.
3. After 2 seconds the blue LED blinks two times to indicate that the calibration procedure has finished.

ATTENTION

Make sure that the nozzles are disconnected and unobstructed.

Reset of Modbus registers procedure:

1. Press button SW2 for 4 seconds until blue LED on the printed circuit board blinks two times and keep pressing this button until the blue LED is blinks three times.
2. The Modbus registers are reset to their default values (factory pre-set).

Fig. 8 Sensor calibration and Modbus register reset tact switch and indications

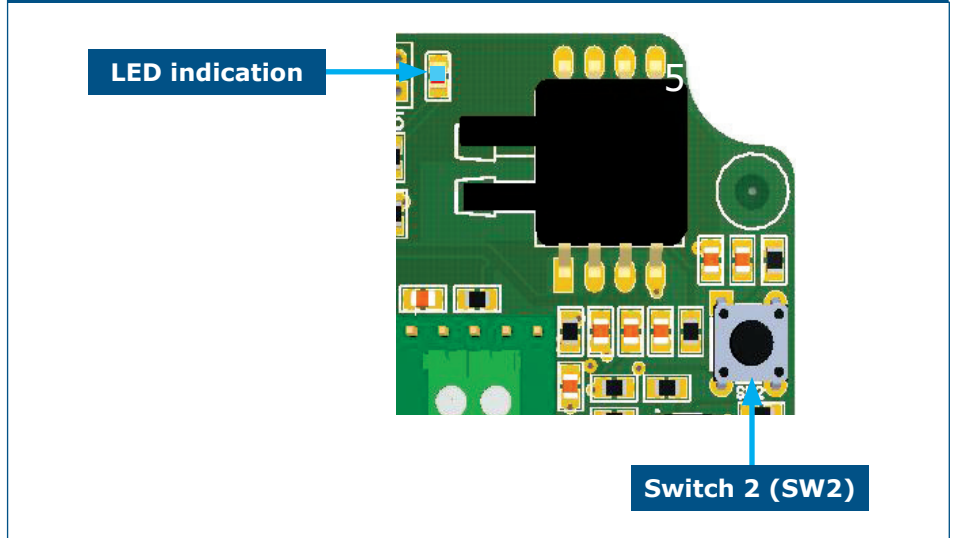

NOTE

Press and hold the tact switch until the LED on the PCB blinks three times. If the tact switch is released after the LED blinks again two times, the device will have carried out a calibration procedure instead of Modbus registers reset procedure.

Kp and Ti tune:

To optimise the functionality of this controller, its behavior and reaction times must correspond to your application. Optimisation can be done by adjusting the Kp (proportional gain) and Ti (integration time) parameters. The auto-tune algorithm automatically calculates the optimal Kp and Ti values for your application. The auto-tune function can be started via Modbus Holding Register 59. If you have extensive knowledge of PI control, you can change Kp and Ti parameters by writing in Modbus Holding Registers 57 and 58. .

VERIFICATION OF THE INSTALLATION INSTRUCTIONS

Continuous green LED indication as shown in **Fig. 9 LED indications** means the unit is supplied. If LED1 is not on, check the connections again.

Blinking blue LED indication as shown in **Fig. 9** means 'Calibration Done' and 'Modbus Parameters Reset' conditions.

In normal operation the blue LED is constantly blinking indicating that the unit is working properly.

NOTE

For more information, click here to refer to the product datasheet - Settings.

Fig. 9 LED indications

Power on / Normal operation	Modbus communication

ATTENTION

The status of the LEDs can be checked only when the unit is energised. Take the relevant safety measures!

SW1: analogue output AO1 mode selection

- 1: 0-10 VDC.
- 2: 0-20 mA.
- 3: PWM (open collector).

SW2: calibration switch zero point and factory pre-set of Modbus registers.

Fig. 10 SMD LEDs

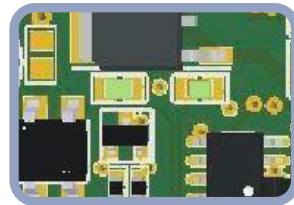

- Blinking green SMD LED for indication of activity on the transmit line.
- Blinking green SMD LED for indication of activity on the receive line.

Open Contact (OC) functionality: selection of active setpoint

Fig. 11 Active Setpoint selection

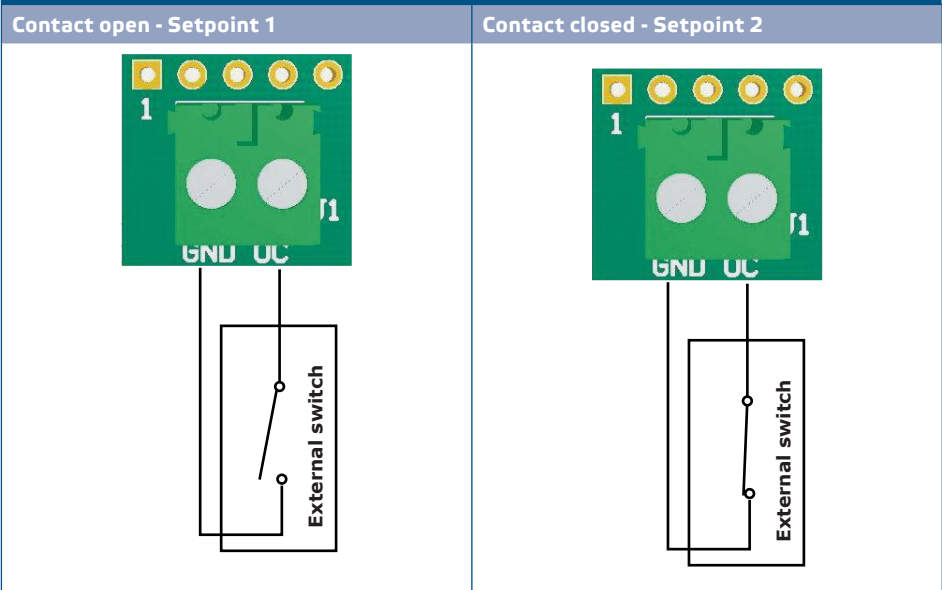

NOTE

The values for setpoint 1 and 2 can be set via Modbus RTU.

TRANSPORT AND STORAGE

Avoid shocks and extreme conditions; stock in original packing.

WARRANTY AND RESTRICTIONS

The warranty against manufacturing flaws is valid for two years starting from the date of delivery. Any alterations or adjustments to the product absolve the manufacturer of all liability. The manufacturer disclaims all liability for typographical or other errors in this document.

MAINTENANCE

In normal conditions this product is maintenance-free. If soiled, clean with a dry or damp cloth. In case of heavy pollution, clean with a non-aggressive product. In these circumstances the unit should be disconnected from the supply. Pay attention that no fluids enter the unit. Only reconnect it to the supply when it is completely dry.

