

HPD | DUAL DIFFERENTIAL PRESSURE TRANSMITTER

Mounting and operating instructions



Table of contents

SAFETY AND PRECAUTIONS	3
PRODUCT DESCRIPTION	4
ARTICLE CODES	4
INTENDED AREA OF USE	4
TECHNICAL DATA	4
STANDARDS	5
OPERATIONAL DIAGRAM	5
WIRING AND CONNECTIONS	5
MOUNTING INSTRUCTIONS IN STEPS	6
VERIFICATION OF INSTALLATION	8
OPERATING INSTRUCTIONS	9
TRANSPORT AND STORAGE	10
WARRANTY AND RESTRICTIONS	10
MAINTENANCE	10

SAFETY AND PRECAUTIONS



Read all the information, the datasheet, the Modbus register map, the mounting and operating instructions and study the wiring and connection diagram before working with the product. For personal and equipment safety, and for optimum product performance, make sure you entirely understand the contents before installing, using, or maintaining this product..



For safety and licensing (CE) reasons, unauthorised conversion and /or modifications of the product are inadmissible.



The product should not be exposed to abnormal conditions, such as: extreme temperatures, direct sunlight or vibrations. Long-term exposure to chemical vapours in high concentration can affect the product performance. Make sure the work environment is as dry as possible; avoid condensation.



All installations shall comply with local health and safety regulations and local electrical standards and approved codes. This product can only be installed by an engineer or a technician who has expert knowledge of the product and safety precautions.



Avoid contacts with energised electrical parts. Always disconnect the power supply before connecting, servicing or repairing the product.



Always verify that you apply appropriate power supply to the product and use appropriate wire size and characteristics. Make sure that all the screws and nuts are well tightened and fuses (if any) are fitted well.



Recycling of equipment and packaging should be taken into consideration and these should be disposed of in accordance with local and national legislation / regulations.



In case there are any questions that are not answered, please contact your technical support or consult a professional.

PRODUCT DESCRIPTION

The HPD series are compact high resolution double differential pressure transmitters, which are equipped with two fully digital pressure transducer designed for a wide range of applications. Air velocity readout is available by connecting an external Pitot tube connection set. All parameters are accessible via Modbus RTU (3SModbus software or Sensistant). They also feature integrated K-factor and 2 analogue / modulating outputs (0–10 VDC / 0–20 mA / 0–100 % PWM).

ARTICLE CODES

Codes	Power supply	Maximum power consumption	Nominal power consumption	I _{max}	Operating range
HPD-F-1K0	18–34 VDC	1,85 W	1,35 W	100 mA	0–1.000 Pa
HPD-F-2K0					0–2.000 Pa
HPD-F-4K0					0–4.000 Pa
HPD-F-10K					0–10.000 Pa
HPD-G-1K0	18–34 VDC /	1,85 W	1,35 W	105 mA	0–1.000 Pa
HPD-G-2K0					0–2.000 Pa
HPD-G-4K0	15–24 VAC ±10 %	3,4 W	2,5 W	230 mA	0–4.000 Pa
HPD-G-10K					0–10.000 Pa

INTENDED AREA OF USE

- Differential pressure measurement in HVAC applications
- Volume flow measurement in HVAC applications
- Air velocity measurement (by using an external PSET-PTX-200 Pitot tube connection set) in HVAC applications
- Differential pressure / volume flow monitoring in clean rooms
- Clean air and non-aggressive, non-combustible gases

TECHNICAL DATA

- 2 built-in digital high resolution differential pressure sensors
- Air velocity can be measured via Modbus RTU (by using an external PSET-PTX-200 Pitot tube connection set)
- 2 selectable analogue / modulating outputs: 0–10 VDC / 0–20 mA / PWM (open collector type):
 - ▶ 0–10 VDC mode: $R_L \geq 50 \text{ k}\Omega$
 - ▶ 0–20 mA mode: $R_L \leq 500 \Omega$
 - ▶ PWM mode: PWM Frequency: 1 kHz, $R_L \geq 50 \text{ k}\Omega$
- Minimum differential pressure range span: 5 Pa
- Minimum volume flow range span: 10 m³/h
- Minimum air velocity range span: 1 m/s
- Selectable response time: 0,1–10 s
- Implemented K-factor
- Selectable internal voltage source for PWM output: 3,3 or 12 VDC
- Differential pressure, air volume or air velocity readout via Modbus RTU
- Selectable minimum and maximum operating ranges
- Modbus registers reset function (to factory pre-set values)
- Modbus RTU communication
- Sensor calibration procedure via tact switch
- Aluminium pressure connection nozzles
- Accuracy: ±2 % of the operating range
- Operating ambient conditions:
 - ▶ Temperature: -5–65 °C
 - ▶ Rel. humidity: < 95 % rH (non-condensing)
- Storage temperature: -20–70 °C

STANDARDS

- EMC Directive 2014/30/EC: CE
 - ▶ EN 61326-1:2013 Electrical equipment for measurement, control and laboratory use - EMC requirements - Part 1: General requirements
 - ▶ EN 61326-2-3:2013 Electrical equipment for measurement, control and laboratory use - EMC requirements - Part 2-3: Particular requirements - Test configuration, operational conditions and performance criteria for transducers with integrated or remote signal conditioning
- WEEE Directive 2012/19/EC
- RoHs Directive 2011/65/EC

OPERATIONAL DIAGRAM

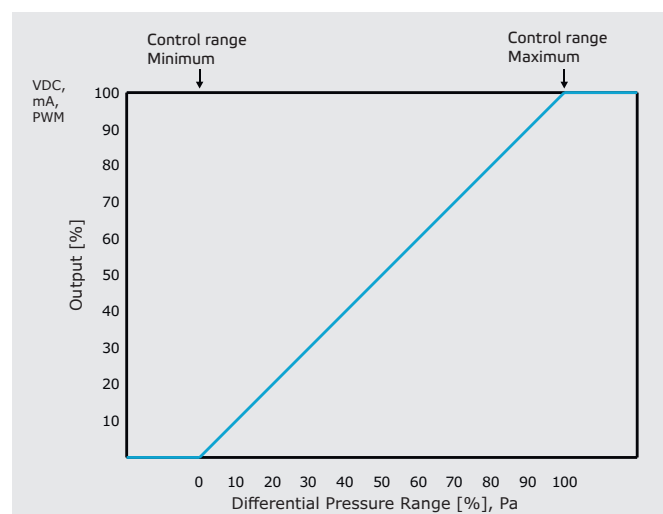

WIRING AND CONNECTIONS

Article type	HPD-F	HPD-G	
Vin	18–34 VDC	18–34 VDC	13–26 VAC
	Ground	Common ground	AC ~
GND	Ground / AC ~		
A	Modbus RTU (RS485), signal A		
/B	Modbus RTU (RS485), signal /B		
AO1	Analogue / modulating output 1 (0–10 VDC / 0–20 mA / PWM)		
GND	Ground AO1	Common ground	
AO2	Analogue / modulating output 2 (0–10 VDC / 0–20 mA / PWM)		
GND	Ground AO2	Common ground	
Connections	Cable cross section	1,5 mm ²	
	Cable gland clamping range	3–6 mm	
	Connecting tube diameter	6 mm	

ATTENTION

The -F version of the product is not suited for 3-wire connection. It has separate grounds for power supply and analogue output. Connecting both grounds together might result in incorrect measurements. Minimum 4 wires are required to connect -F type sensors.

The -G version is intended for 3-wire connection and features a 'common ground'. This means that the ground of the analogue output is internally connected with the ground of the power supply. For this reason, -G and -F types cannot be used together on the same network. Never connect the common ground of -G type articles to other devices powered by a DC voltage. Doing so might cause permanent damage to the connected devices.

MOUNTING INSTRUCTIONS IN STEPS

Before you start mounting the unit, read carefully "Safety and Precautions". Choose a smooth surface for installation (a wall, panel, etc.) and follow these steps:

1. Unscrew the front cover of the enclosure to remove it.
2. Fix the enclosure onto the surface by means of suitable fasteners while adhering to the mounting dimensions shown in Fig. 1 and the correct mounting position shown in Fig. 2 below.

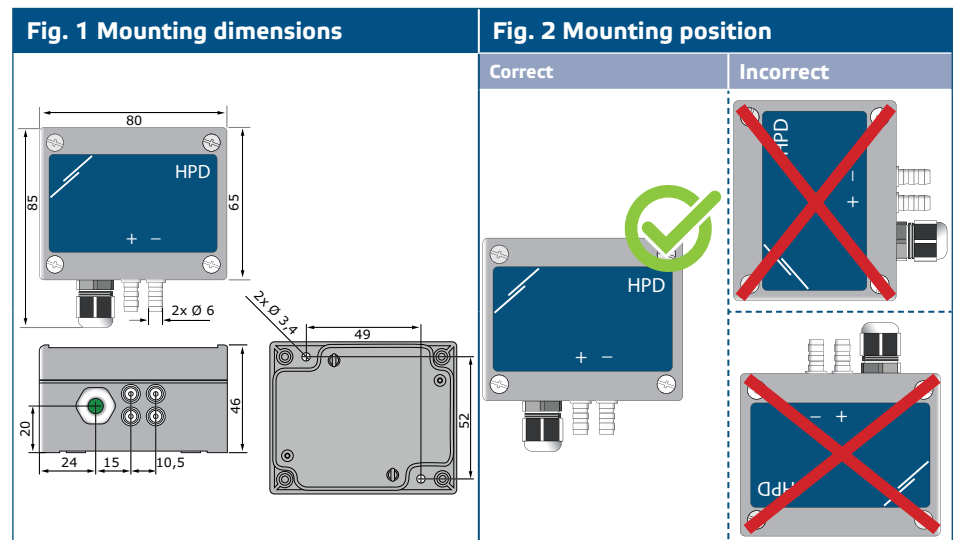

3. Insert the cable into the cable gland.
4. Connect as shown in Fig. 3 Connections adhering to the information in section "Wiring and connections".

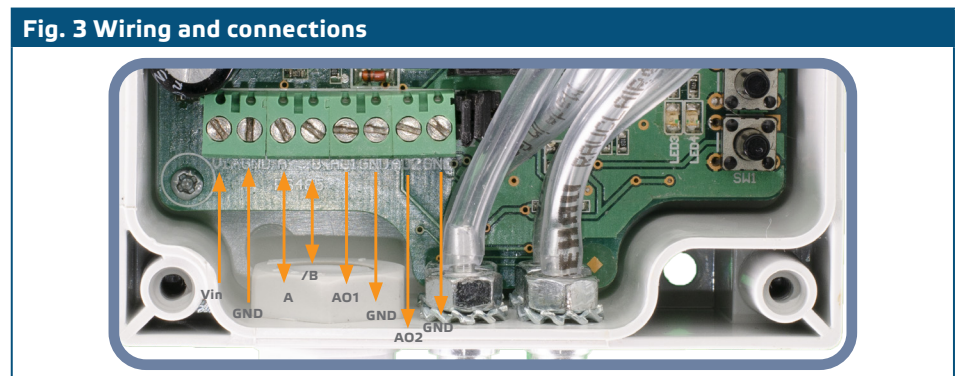

5. Switch on the power and perform a calibration procedure (refer to section "OPERATING INSTRUCTIONS").
6. Connect the nozzles to the duct (see Fig. 4). Depending the application you must use a specific connection set to connect the nozzles of the unit to the duct:
 - 6.1 To measure differential pressure, use PSET-QF or PSET-PVC set (pressure measurement is the unit default setting).

- 6.2** To measure volume flow, use PSET-PT Pitot tube connection set, PSET-QF or PSET-PVC connection set. If you use PSET-PT, you should enter the duct cross sectional area [cm²] in Modbus holding register 63 for sensor module 1 or in holding register 83 for sensor module 2. If you use PSET-QF or PSET-PVC, enter the K-factor of the fan (provided by the fan /motor manufacturer) in Modbus holding register 62 for sensor module 1 or in holding register 82 for sensor module 2.

In case the K-factor is not known, volume flow is calculated from a duct cross sectional area (holding register 63 for sensor module 1 or in holding register 83 for sensor module 2) multiplied by air velocity (Pitot air velocity (holding register 64) should be enabled and Pitot tube connected).

- 6.3** To measure air velocity, use PSET-PT set and enable Pitot tube air velocity via holding register 64 for sensor module 1 or in holding register 84 for sensor module 2. In this case the K-factor of the fan has to be 0.

Fig. 4 Connecting with accessories

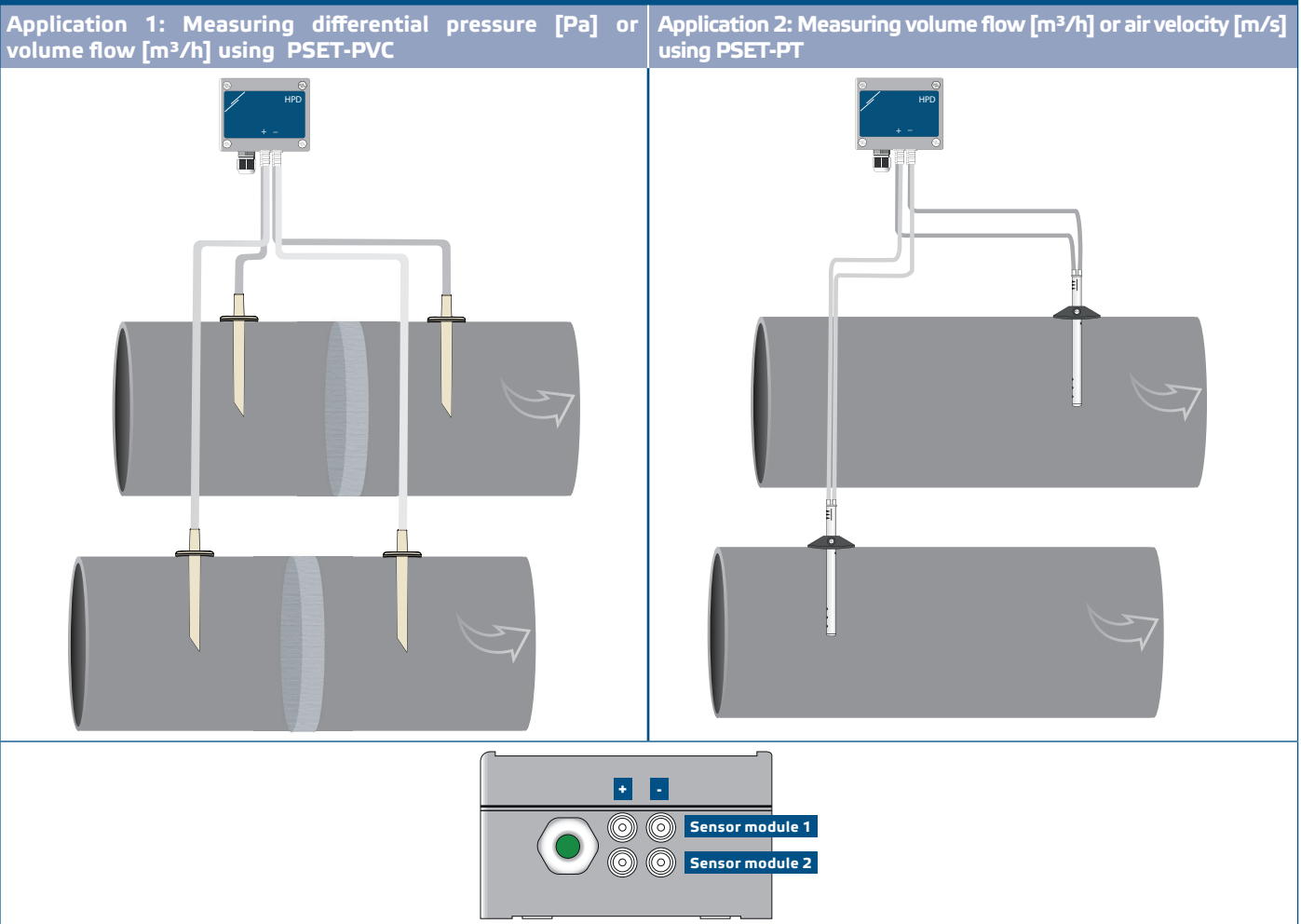

- 7.** Connect the nozzles with the tubing.
- 8.** Switch on the power supply.

NOTE

For sensor calibration and Modbus registers reset procedures, refer to section "Operating instructions".

PWM voltage selection:

- When the internal pull-up resistors (JP1 for sensor module 1 and JP2 for sensor module 2) are connected, the voltage source is set via Modbus holding register 54 for sensor module 1 and holding register 74 for sensor module 2, i.e. 3,3 VDC or 12 VDC. See **Fig. 5 Pull-up resistor jumpers**.

Fig. 5 Pull-up resistor jumpers

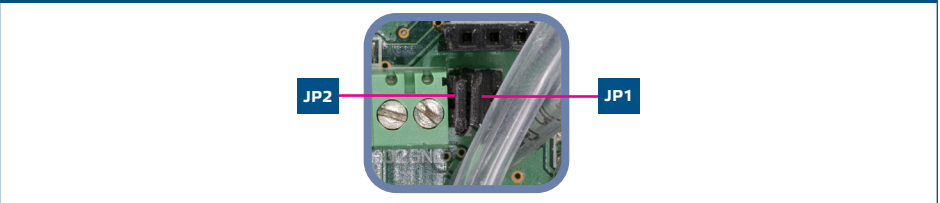

- When JP1 and JP2 are disconnected, the output type is Open collector. See Fig. 6 PWM (Open collector) connection example.
- Only when JP1 and JP2 are not connected and the analogue outputs (AO1 and AO2) are assigned as PWM output (via holding registers 54 and 74 - see the Modbus Map), external pull-up resistors are used.

Fig. 6 PWM (Open collector) connection example

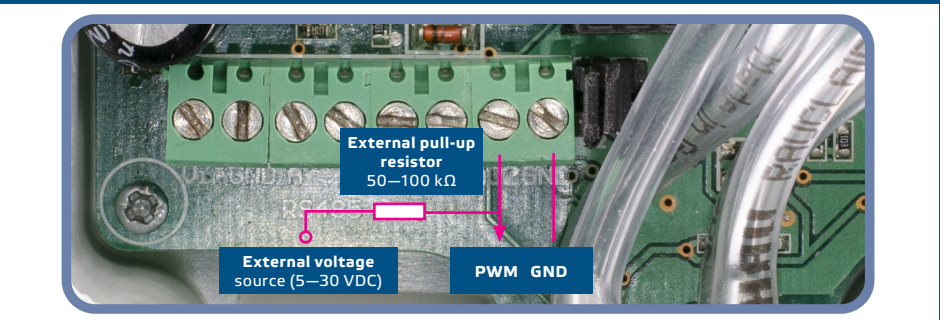

Optional settings

To assure correct communication, the NBT needs to be activated in only two devices on the Modbus RTU network. If necessary, enable the NBT resistor via 3SModbus or Sensistant (Holding register 9).

Example 1

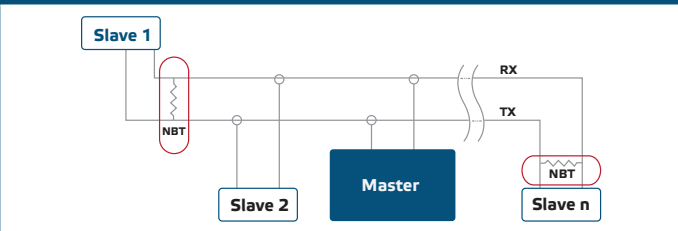

Example 2

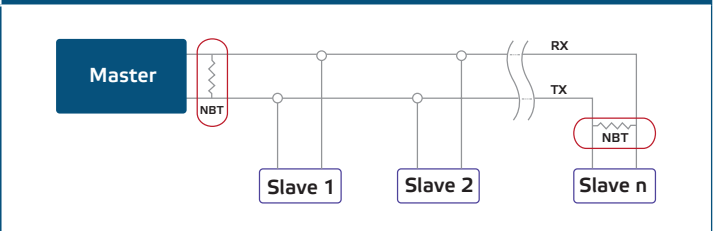

NOTE

On a Modbus RTU network, two bus terminators (NBTs) need to be activated.

- Put back the front cover and secure it with the screws.
- Customise the factory settings to the desired ones via the 3SModbus software or the Sensistant configurator. For the default factory settings, see Modbus register map.

NOTE

For the complete Modbus register data, refer to the product Modbus Register Map, which is a separate document attached to the article code on the website and contains the registers list. Products with earlier firmware versions may not be compatible with this list.

VERIFICATION OF INSTALLATION

After switching on the power supply, the green ON/OFF LED on the printed circuit board must be on solid indicating that the unit is powered (Fig. 7 Operating indication). If the LED is OFF, check the connections.

Blinking green RX and TX LEDs indicate that the unit has detected a Modbus network (**Fig. 8**). If they do not blink, check the connections.

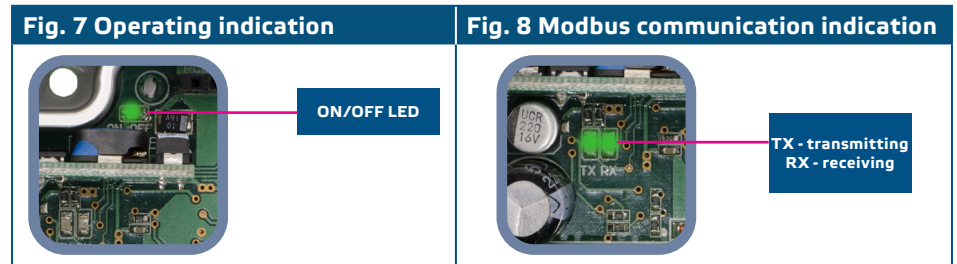

ATTENTION

The status of the LEDs can be checked only when the unit is powered. Take the relevant safety measures!

OPERATING INSTRUCTIONS

NOTE

For detailed information and settings, refer to the product Modbus register map, which is attached to the article code on our website.

Calibration procedure:

- 1. Sensor module 1:**
 - 1.1 Disconnect the nozzles and make sure they are not clogged.
 - 1.2 There are two options for starting the calibration process:
 - Either write "1" in holding register 70 or press tact switch SW1 for about 5 seconds until the blue LED3 on the printed circuit board blinks twice and release it (see **Fig. 9** *Sensor calibration and Modbus register reset tact switch and indication*).
 - 1.3 After the calibration is done, the blue LED3 will blink twice once again to indicate that the calibration procedure has finished.
- 2. Sensor module 2:**
 - 2.1 Disconnect the nozzles and make sure they are not clogged.
 - 2.2 There are two options for starting the calibration process:
 - Either write "1" in holding register 90 or press tact switch SW2 for about 5 seconds until the blue LED4 on the printed circuit board blinks twice and release it (see **Fig. 9** *Sensor calibration and Modbus register reset tact switch and indication*).
 - 2.3 After the calibration is done, the blue LED4 will blink twice once again to indicate that the calibration procedure has finished.

ATTENTION

Make sure that the nozzles are disconnected and unobstructed.

Reset of Modbus holding registers procedure:

1. There are two options for starting the Modbus reset process:
 - Write '1' in holding register 10 or press tact SW1 until the blue LED3 on the printed circuit board blinks two times and do not release the switch until LED3 blinks again three times.
2. All Modbus registers, except the communication related registers 1–9, are reset to their default values (factory pre-set).

Fig. 9 Sensor calibration and Modbus register reset tact switches and indication

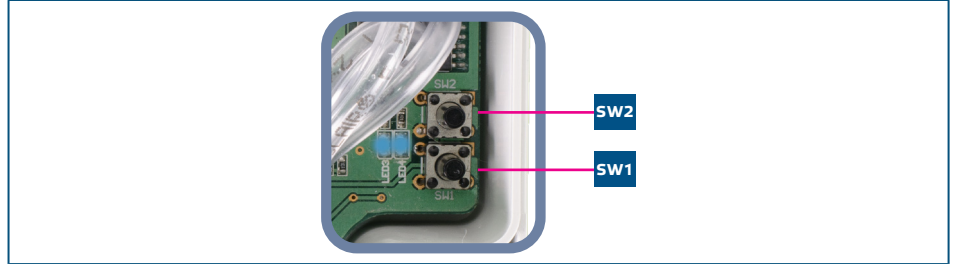

ATTENTION

Press and hold the tact switch until both LEDs on the PCB blink twice and hold it until both LEDs blink again three times. If the tact switch is released before the LED blinks again three times, the sensor will have carried out a calibration procedure instead of Modbus registers reset procedure.

TRANSPORT AND STORAGE

Avoid shocks and extreme conditions; stock in original packing.

WARRANTY AND RESTRICTIONS

Two years from the delivery date against defects in manufacturing. Any modifications or alterations to the product after the date of publication relieve the manufacturer of any responsibilities. The manufacturer bears no responsibility for any misprints or mistakes in this data.

MAINTENANCE

In normal conditions this product is maintenance-free. If soiled, clean with a dry or damp cloth. In case of heavy pollution, clean with a non-aggressive product. In these circumstances the unit should be disconnected from the supply. Pay attention that no fluids enter the unit. Only reconnect it to the supply when it is completely dry.