

DR | ELECTRONIC FAN SPEED CONTROLLER, DIN RAIL MOUNTING

Mounting and operating instructions

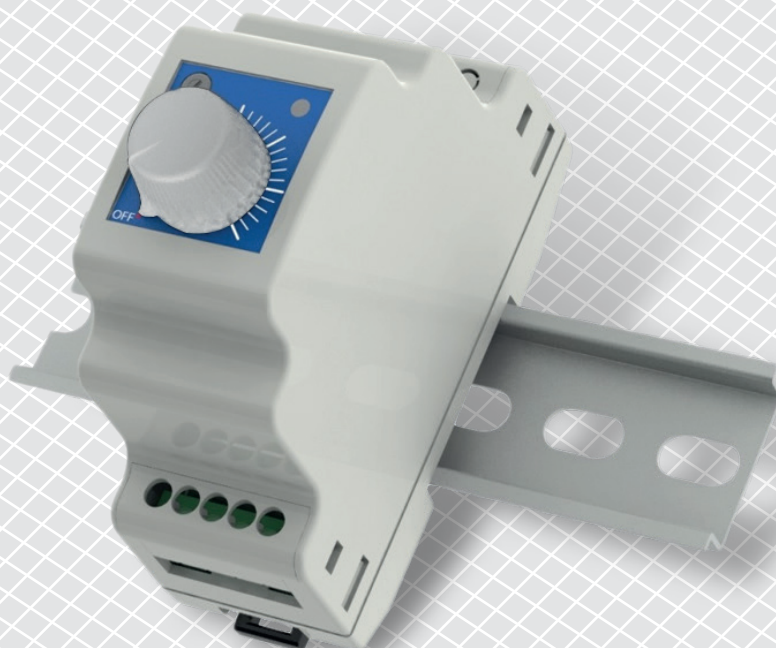

Table of contents

SAFETY AND PRECAUTIONS	3
PRODUCT DESCRIPTION	4
ARTICLE CODES	4
INTENDED AREA OF USE	4
TECHNICAL DATA	4
STANDARDS	4
OPERATIONAL DIAGRAM	5
WIRING AND CONNECTIONS	5
MOUNTING & OPERATING INSTRUCTIONS IN STEPS	6
VERIFICATION OF THE INSTALLATION INSTRUCTIONS	7
TRANSPORT AND STOCK KEEPING INFORMATION	7
WARRANTY INFORMATION AND RESTRICTIONS	7
MAINTENANCE	7

SAFETY AND PRECAUTIONS



Read all the information, the datasheet, Modbus map, mounting and operating instructions and study the wiring and connection diagram before working with the product. For personal and equipment safety, and for optimum product performance, make sure you entirely understand the contents before installing, using or maintaining this product.



For safety and licensing (CE) reasons, unauthorised conversion and / or modifications of the product are inadmissible.



The product should not be exposed to abnormal conditions, such as extreme temperatures, direct sunlight or vibrations. Long-term exposure to chemical vapours in high concentration can affect the product performance. Make sure the work environment is as dry as possible; avoid condensation.



All installations shall comply with local health and safety regulations and local electrical standards and approved codes. This product can only be installed by an engineer or a technician who has expert knowledge of the product and safety precautions.



Avoid contacts with energised electrical parts. Always disconnect the power supply before connecting, servicing or repairing the product.



Always verify that you apply appropriate power supply to the product and use appropriate wire size and characteristics. Make sure that all the screws and nuts are well tightened and fuses (if any) are fitted well.



Recycling of equipment and packaging should be taken into consideration and these should be disposed of in accordance with local and national legislation / regulations.



In case there are any questions that are not answered, please contact your technical support or consult a professional.

PRODUCT DESCRIPTION

The DRX / DRY controller controls manually the speed of single phase (230 VAC / 50–60 Hz) voltage controllable motors / fans from high to low (DRX) or from low to high output (DRY). It is suitable for DIN rail mounting (DIN EN 50022). Multiple fans can be connected as long as the current limit is not exceeded.

ARTICLE CODES

Code	Regulation	Max. rated current	Max. load L1	Fuse 5*20 mm
DRY-1-15-AT	min. to max.	1,5 A	0,5 A	3,15 A
DRX-1-15-AT	max. to min.	1,5 A	0,5 A	3,15 A
DRY-1-25-AT	min. to max.	2,5 A	0,5 A	5,0 A
DRX-1-25-AT	max. to min.	2,5 A	0,5 A	5,0 A

INTENDED AREA OF USE

- Speed control of motors / fans in ventilation systems
- For indoor use only

TECHNICAL DATA

- Supply: 230 VAC $\pm 10\%$ / 50–60 Hz
- Unregulated output load (L1): 230 VAC / max. 0,5 A
- Regulated output to motor / fan, U:
 - ▶ max. load: 1,5 A for DRX / DRY-1-15-AT
 - ▶ max. load: 2,5 A for DRX/DRY-1-25-AT
- Speed control:
 - ▶ DRX – from maximum to minimum
 - ▶ DRY – from minimum to maximum
- Minimum speed adjustment by trimmer: 60–230 VAC
- Green operating LED indication: ON / OFF
- Enclosure:
 - ▶ DIN rail mounting (DIN EN 50022)
 - ▶ ABS/PC, grey (RAL 7035)
- Protection standard: IP30 (according to EN 60529)
- Operating ambient conditions:
 - ▶ temperature: 0–40 °C
 - ▶ relative humidity: < 80 % rH (non-condensing)
- Storage temperature: -14–50 °C

STANDARDS

- Low Voltage Directive 2014/35/EU CE
 - ▶ EN 60335-1:2012 Household and similar electrical appliances - Safety - Part 1: General requirements. Amendment A11:2014 and AC:2014 to EN 60335-1:2012
 - ▶ EN 61558-1:2005 Safety of power transformers, power supplies, reactors and similar products - Part 1: General requirements and tests. Amendment AC:2006 and A1:2009 to EN 61558-1:2005

- EMC Directive 2014/30/EU:
 - ▶ EN 61000-6-2:2005 Electromagnetic compatibility (EMC) - Part 6-2: Generic standards - Immunity for industrial environments. Amendment AC:2005 to EN 61000-6-2:2005
 - ▶ EN 61000-6-3:2005 Electromagnetic compatibility (EMC) - Part 6-3: Generic standards - Emission standard for residential, commercial and light-industrial environments. Amendment A1:2011 and AC:2012 to EN 61000-6-3:2007
- WEEE Directive 2012/19/EU
- RoHs Directive 2011/65/EU

OPERATIONAL DIAGRAM

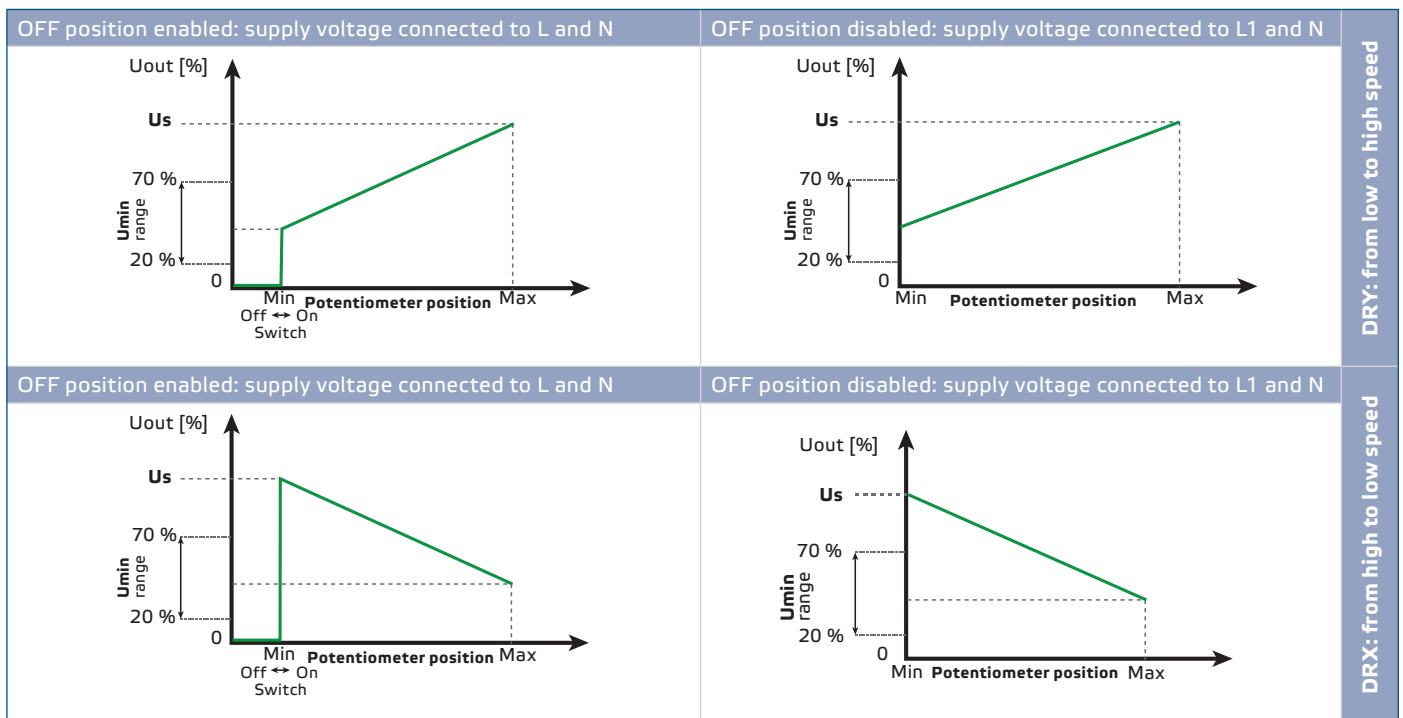

WIRING AND CONNECTIONS

L, N	Supply voltage, 230 VAC ±10 % / 50–60 Hz
U, N	Regulated output
L1, N	Unregulated output 230 VAC / 0,5 A
Connections	Cable cross section: max. 2,5 mm ²

NOTE

To disable the OFF position, connect the 230 VAC supply voltage to the unregulated output L1 and N. In this case, do not connect the power supply to L and N.

MOUNTING & OPERATING INSTRUCTIONS IN STEPS

Before you start mounting the unit, read carefully “**Safety and Precautions**”. Then proceed with the following mounting steps:

1. Switch off the power supply.
2. Mount the controller on a standard 35 mm DIN rail. Pull the locking clip before you place the unit onto the rail, and then release the locking clip back to its original position to fix the enclosure to the rail. See **Fig. 1** *DIN rail locking clip*, **Fig. 2** *Mounting dimensions* and **Fig. 3** *Mounting position*.

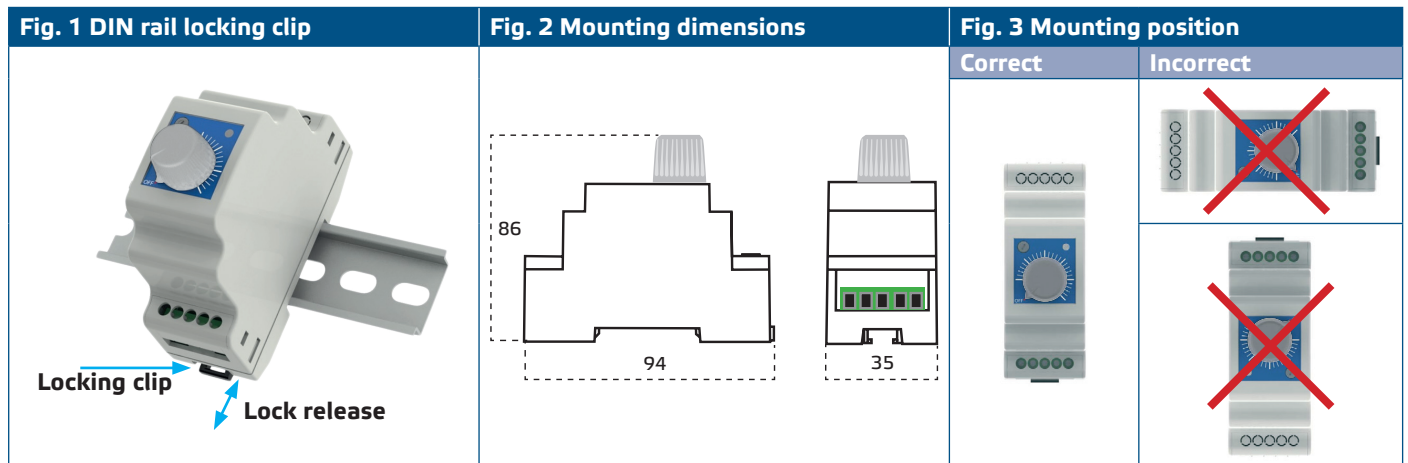

3. Do the wiring according to the wiring diagram (see **Fig. 4**) using the legend information from section “**Wiring and connections**”.

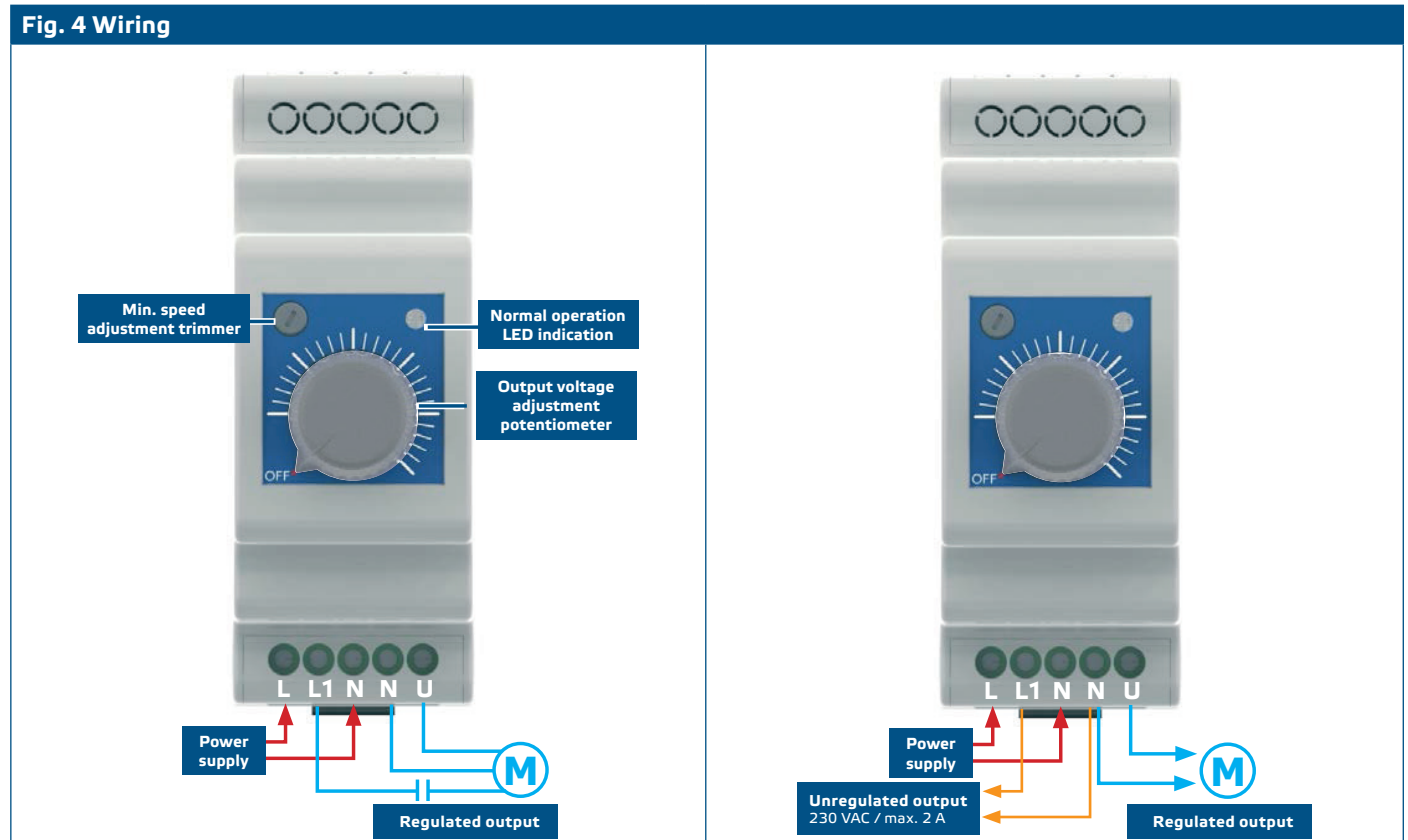

4. Switch on the power supply.
5. Set the required output voltage with the help of the potentiometer on the front cover. Adjust the minimum speed with the trimmer (if necessary). The factory pre-set is 100 VAC. See **Fig. 1**.

VERIFICATION OF THE INSTALLATION INSTRUCTIONS

When you switch on the power supply the LED for operating indication shown in **Fig.4** should give out constant green light. If this is not the case, check the connections.

TRANSPORT AND STOCK KEEPING INFORMATION

Avoid shocks and extreme conditions; stock in original packing.

WARRANTY INFORMATION AND RESTRICTIONS

Two years from the delivery date against defects in manufacturing. Any modifications or alterations to the product after the date of publication relieve the manufacturer of any responsibilities. The manufacturer bears no responsibility for any misprints or mistakes in this data.

MAINTENANCE

In normal conditions this product is maintenance-free. If soiled, clean with a dry or damper cloth. In case of heavy pollution, clean with a non-aggressive product. In these circumstances the unit should be disconnected from the supply. Pay attention that no fluids enter the unit. Only reconnect it to the supply when it is completely dry.