

ARM-T | ANALOGUE TO RELAY CONVERTER

Mounting and operating instructions



Table of contents

1. SAFETY AND PRECAUTIONS
.....

2. PRODUCT DESCRIPTION
.....

3. ARTICLE CODES
.....

4. INTENDED AREA OF USE
.....

5. TECHNICAL DATA
.....

6. STANDARDS
.....

7. WARNINGS AND ATTENTION POINTS
.....

8. MOUNTING INSTRUCTIONS IN STEPS
.....

9. WIRING AND CONNECTIONS
.....

10. OPERATIONAL DIAGRAMS
.....

11. VERIFICATION OF INSTALLATION
.....

12. TROUBLESHOOTING
.....

13. FREQUENTLY ASKED QUESTIONS (FAQs)
.....

14. TRANSPORT AND STORAGE
.....

15. WARRANTY AND RESTRICTIONS
.....

16. MAINTENANCE
.....

1. SAFETY AND PRECAUTIONS



Read all the information in this manual, in the datasheet and in the Modbus Register Map before working with the product. For personal and equipment safety and for optimum product performance, make sure you fully understand the content before installing, using or servicing this product.



For safety and licensing (CE) reasons, unauthorised conversions and / or modifications of the product are inadmissible.



The product should not be exposed to abnormal conditions, such as extreme temperatures, direct sunlight or vibrations. Long-term exposure to chemical vapours in high concentrations can affect the product performance. Make sure the work environment is as dry as possible and avoid condensation.



All installations must comply with local health and safety regulations and local electrical standards and approved codes. This product should only be installed by an engineer or a technician with expert knowledge of the product and safety precautions.



Avoid contact with energised electrical parts. Always disconnect the power supply before connecting, servicing or repairing the product.



Always check that you are connecting the correct power supply to the product and use wires with the correct characteristics and cross-section. Make sure all screws and nuts are properly tightened and fuses (if any) are in place.



Consideration should be given to recycling the equipment and packaging. These should be disposed of in accordance with local and national laws and regulations.



If there are questions that are not answered, contact your technical support or consult a professional.

2. PRODUCT DESCRIPTION

The ARM-T are solid-state relay modules that convert an analogue control signal into a reliable ON/OFF relay output. The device monitors an analogue input signal (0–10 VDC, 0–20 mA, or PWM) and switches the relay when a user-defined threshold is reached. Switching behavior, including logic and hysteresis, can be configured to ensure stable operation and prevent unwanted relay toggling.

The relay output is a voltage-free (dry-contact) output suitable for controlling external equipment such as fans, valves, or contactors. An override function allows the relay to be forced permanently ON or OFF when required. All measurements, status information, and configuration settings are accessible via Modbus RTU communication over an RS-485 interface, enabling easy integration into SenteraWeb, building management systems, or other Modbus-based controllers. The device is powered by a 18–34 VDC supply and features low power consumption.

Two product variants are available: ARM-TL-1 “Low Power”/ ARM-TH-1 “High Power”

3. ARTICLE CODES

Article code	Power type
ARM-TL-1	24 VDC (18 – 34 VDC)
ARM-TH-1	

4. INTENDED AREA OF USE

- Built for the HVAC industry, can be used both in industrial as well as domestic environments; Fan speed control in HVAC applications.
- Demand-Controlled Ventilation (DCV) and industrial automation

5. TECHNICAL DATA

- Supply voltage: 24 VDC (18 – 34 VDC)
- Maximum current consumption: 50mA
- Reverse voltage protection
- Modbus RTU communication
- Firmware updating via Modbus RTU communication
- Analogue input:
 - 0 – 10 VDC (load resistance $\geq 1 \text{ k}\Omega$)
 - 0 – 20 mA (load resistance $\leq 250 \Omega$)
 - PWM Push-Pull (load resistance $\geq 1 \text{ k}\Omega$)
 - frequency = 1kHz - 8kHz, voltage level 3.3V - 12V
- Device status indication: RGB LED or Modbus RTU
- Operating conditions
 - Temperature: -10°C to 50°C
 - Relative humidity: 10% to 90% (non-condensing)
- Enclosure
 - Ingress protection: IP65 , Acrylonitrile Butadiene Styrene (ABS) plastic enclosure
 - Colour: Grey (RAL 7035)

6. STANDARDS

- Low Voltage Directive 2014/35/EU
- Electromagnetic Compatibility (EMC) Directive 2014/30/EU
- Commission Delegated Directive (EU) 2015/863 (RoHs 3) of 31 March 2015 amending Annex II to Directive 2011/65/EU of the European Parliament and of the Council as regards the list of restricted substances
- WEEE Directive 2012/19/EU



7. WARNINGS AND ATTENTION POINTS

- Avoid the device mounting in locations affected by direct sunlight.
- Turn off a power supply before all servicing and maintenance.
- Applying overvoltage will cause improper operation or failure to the internal circuit.
- Do not short-circuit the terminals or the input and output wiring.
- During operation, the unit must be closed.
- If the unit does not work according to the instructions, the wiring connections, supply voltage and settings need to be checked.

8. MOUNTING INSTRUCTIONS IN STEPS

Before you start mounting the unit, read carefully "Safety and Precautions".

Follow these steps:

1. Switch off the power supply.
2. Open the unit by gently removing the front cover.
3. Secure the device firmly onto a flat, stable surface for optimal performance. Mind the correct position and mounting dimensions shown in **Fig. 1** and **Fig. 2**.
4. Verify your power supply to ensure it matches the required input voltage rating.

Fig. 1 Mounting dimensions

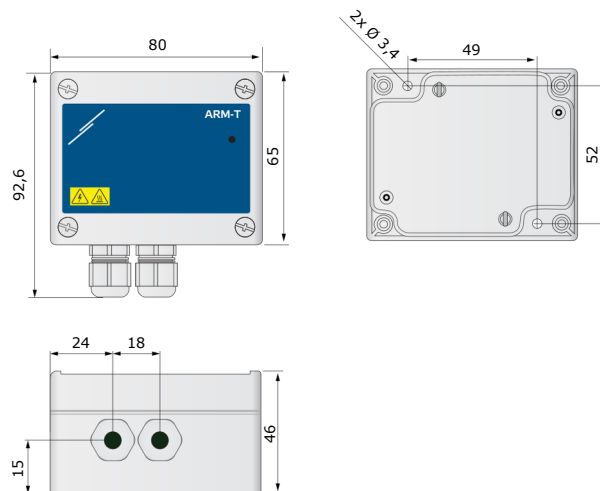
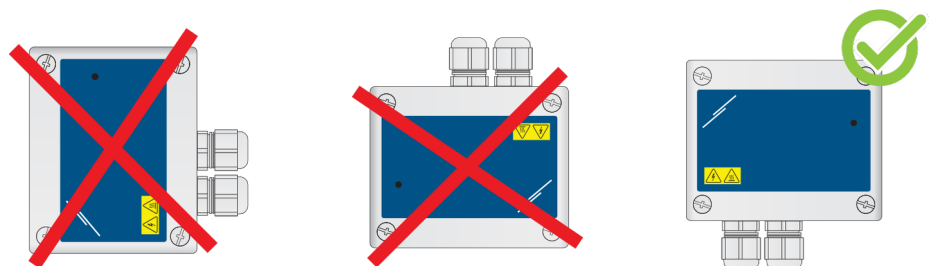

Fig. 2 Mounting position



5. Guide the cables neatly through the integrated cable glands for a clean, secure setup.
6. Do the wiring according to the wiring diagram — see **Fig. 3** while adhering to the information from section “Wiring and connections”.
7. Reattach the cover and fasten it securely using the supplied screws.
8. Tighten the cable gland to ensure a watertight seal.
9. Switch on the power supply.

9. WIRING AND CONNECTIONS

Fig. 3 Wiring diagram

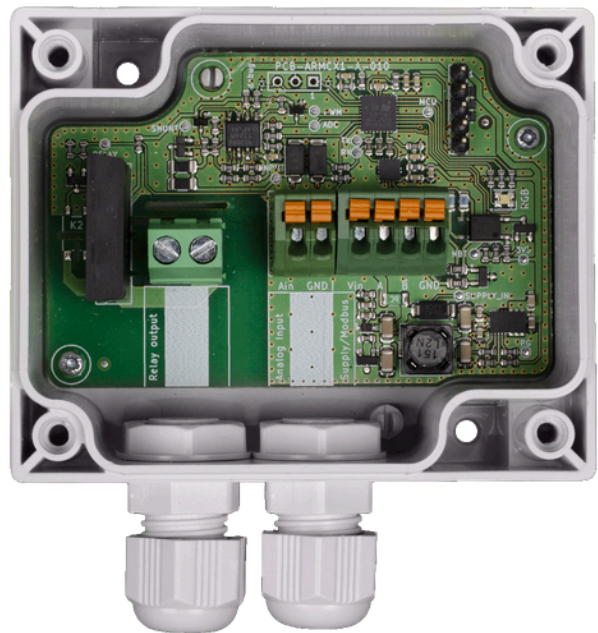

ARM-TH-1

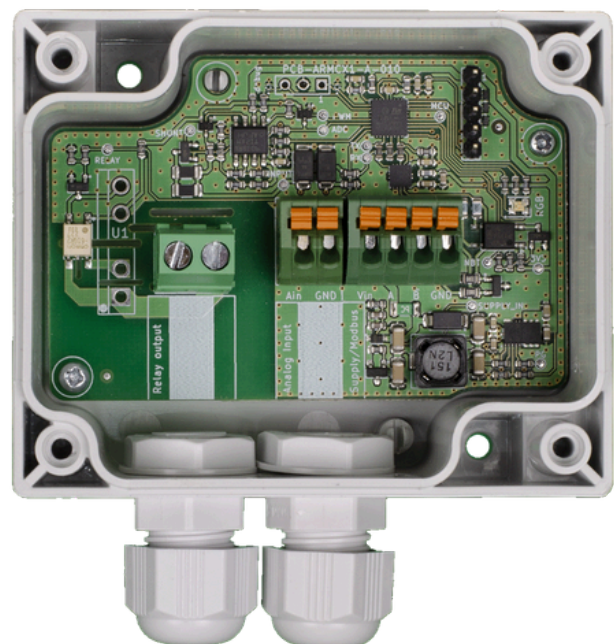

ARM-TL-1

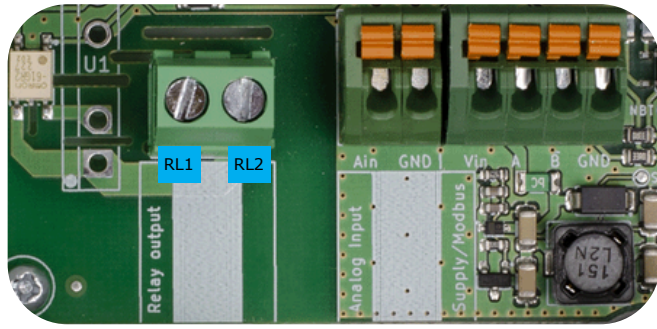

Screw terminal block

RL1		Relay output pin 1
RL2		Relay output pin 2
Contact ratings	ARM-TL-1	0-48 VDC 1,3 A
	ARM-TH-1	20-240 VAC 2 A
Cable characteristics		Cable cross section: 1,5-2,5 mm ²

Spring terminal block

Ain, GND		Analogue Input signal
Cable characteristics		Cable cross section: 0,5 mm ²

Spring terminal block

Vin		Supply voltage: 24 VDC
A, /B		Modus RTU (RS485)
GND		Common Ground
Cable characteristics		Cat5 or EIB cable

Optional settings

The Network Bus Termination (NBT) Resistor is controlled via Modbus RTU and is disconnected by default. For correct communication, the NBT needs to be activated only in the two furthest devices on the Modbus RTU network. If necessary, enable the NBT resistor through SenteraWeb via Holding register 9.

Example 1

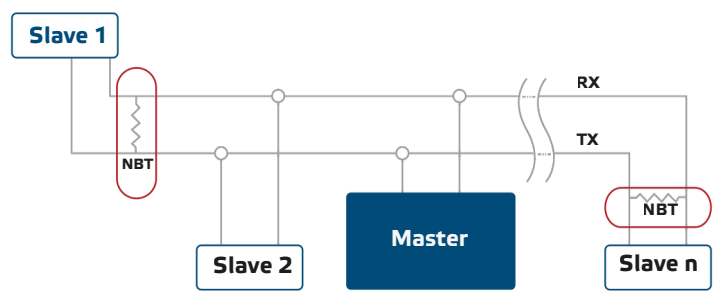

Example 2

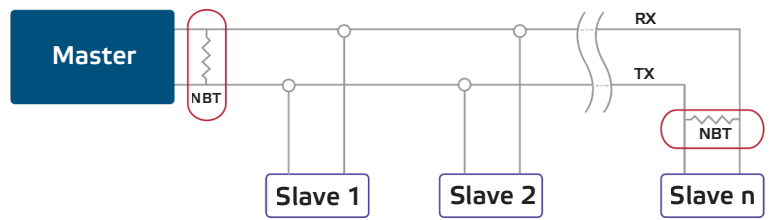

NOTE

On a Modbus RTU network, two bus terminators (NBTs) need to be activated.

10. OPERATIONAL DIAGRAMS

Fig. 4 Operational diagram

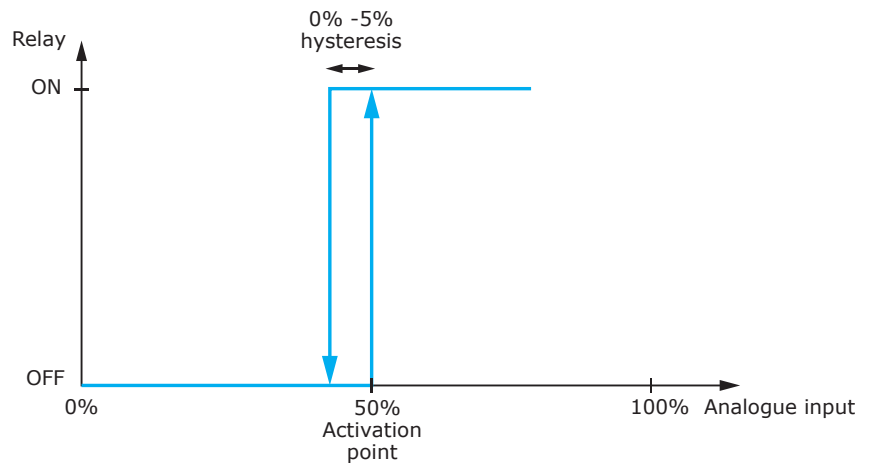

The relay activation threshold is adjustable. By default, it is set to 50 %. When the threshold is set to 50 %, the relay will be activated once the input reaches 50 %. The activation point can be configured via parameter HR34.

11. VERIFICATION OF INSTALLATION

If your unit does not function as expected, please check the connections or refer to the **“Troubleshooting”** section.

12. TROUBLESHOOTING

NOTE

To ensure smooth installation and reliable operation, follow the troubleshooting guidelines below. Each step is designed to be simple, independent, and easy to follow—helping you quickly identify and resolve potential issues. Following these simple checks will help you get your device up and running quickly and ensure optimal performance in your application.

No Visible Signs of Operation

- **How to recognise this issue?**
 - The on-board LED is not illuminated.
 - The device is not detected on the Modbus network.
- **How to solve this issue?**

Verify that:

 - Ensure the power supply is switched ON.
 - Confirm that the device is properly connected to the power source
 - Verify that the supply cable pinout is correct.
 - Measure and confirm that ± 24 V is present at the device terminals (Vin and GND).

No Modbus Communication

- **How to recognise this issue?**
 - The device is not detected by the Modbus master.
- **How to solve this issue?**

Verify that:

 - Ensure correct RS-485 wiring (A to A, B to B) on both ends.
 - Confirm that the cable length does not exceed 1,000 meters.
 - Verify that the Modbus master communication settings are correct (baud rate, parity, etc.).
 - Check that the device slave ID matches the one expected by the Modbus master.
 - Make sure there are no duplicate slave IDs on the same network.
 - Test communication using a broadcast read command (slave ID = 0).
 - For isolation, connect the device to a separate Modbus network without other devices and test again.

Analogue Input Issues

- **How to recognise this issue?**
 - The measured analogue input value (IR11) remains at 0 (below 0.5%).
 - The value remains at 100%.
 - The reading appears inaccurate.
- **How to solve this issue?**

Verify that:

 - Ensure the analogue input cable is properly connected to the signal source.
 - Confirm that the signal type matches the configured input type (0–10 VDC, 0–20 mA, or PWM).

Relay Operation Issues

- **How to recognise this issue?**
 - The relay does not activate.
 - The relay switches ON when it should be OFF (or vice versa).
 - The relay switches rapidly ON and OFF.
 - The relay does not switch OFF when the input signal drops below the threshold.
- **How to solve this issue?**

Verify that:

 - Ensure the relay-to-load wiring is secure.
 - Verify the “inverted” setting (HR33).
 - Check and adjust the hysteresis setting (HR35) if needed.
 - Confirm that the connected load operates within the relay specifications for your device:
- ARM-TH-1 (high-voltage relay):
 - Minimum: 20 VAC (rms), 100 mA
 - Maximum: 240 VAC (rms), 2 A
- ARM-TL-1 (low-voltage relay):
 - DC voltage up to 48 VDC
 - AC voltage up to 34 Vrms (48 Vpeak)

Fig. 5 Settings and indications

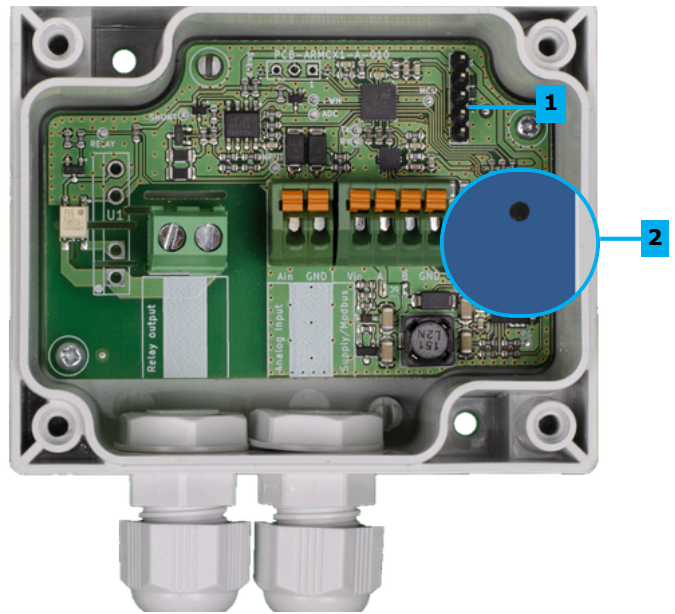

1. PROG header, P1		Put a jumper onto pins 1 and 2 and wait for at least 5 seconds to reset the Modbus communication parameters
On-board LED Indication		
2. RGB LED	Continuous white	Relay OFF
	Continuous green	Relay ON
	Red Blinking	Alarm / Error
	Blue Blinking	Bootloader mode for firmware update

13. FREQUENTLY ASKED QUESTIONS (FAQs)

What does the ARM-T module do?

This module converts an analogue input signal into a relay output signal based on a defined threshold. When the signal reaches a defined threshold, the relay switches. The module monitors one analogue input signal (0–10 Volt, 0–20 mA, or PWM). The threshold can be adjusted via Modbus (HR34), and the signal type can be selected via HR21. Configuration, remote control and firmware updates are done via Modbus RTU communication.

How does the Solid State Relay work?

The ARM-TH uses a Solid State Relay (SSR) instead of a mechanical relay. It switches when the configured analogue threshold is exceeded. Because it has no moving parts, it operates silently, reliably, and without mechanical wear. Unlike mechanical relays, which use physical contacts that can wear out over time due to stress and arcing, an SSR switches electronically using semiconductor components. This makes it faster, more durable, and more resistant to vibration and frequent switching. It also provides electrical isolation between the control and load sides, protecting sensitive electronics.

What is the intended area of use?

This module is designed for HVAC systems and industrial automation. It is commonly used in Domestic Controlled Ventilation (DCV) systems where values such as CO₂, temperature, humidity, or CO must trigger an action. Typical applications include fan control, alarm activation, and switching on/off heaters, dampers, dehumidifiers, pumps, or warning lights. The module acts as a simple interface between sensors with analogue output and switching devices.

14. TRANSPORT AND STORAGE

Avoid shocks and extreme conditions; stock in original packaging.

15. WARRANTY AND RESTRICTIONS

Two years from the delivery date against defects in manufacturing. Any modifications or alterations to the product after the production date relieve the manufacturer of any responsibilities. The manufacturer bears no responsibility for any misprints or mistakes in this data.

16. MAINTENANCE

In normal conditions, this product is maintenance-free. If soiled, clean with a dry or damp cloth. In case of heavy pollution, clean with a non-aggressive product. In these circumstances, the unit should be disconnected from the supply. Pay attention that no fluids enter the unit. Only reconnect it to the supply when it is completely dry.

