

ARM-T

Analogue to relay converter



Description

The ARM-T are solid-state relay modules that convert an analogue control signal into a reliable ON/OFF relay output.

The device monitors an analogue input signal (0–10 VDC, 0–20 mA, or PWM) and switches the relay when a user-defined threshold is reached. Switching behavior, including logic and hysteresis, can be configured to ensure stable operation and prevent unwanted relay toggling.

The relay output is a voltage-free (dry-contact) output suitable for controlling external equipment such as fans, valves, or contactors. An override function allows the relay to be forced permanently ON or OFF when required. All measurements, status information, and configuration settings are accessible via Modbus RTU communication over an RS-485 interface, enabling easy integration into SenteraWeb, building management systems, or other Modbus-based controllers. The device is powered by a 18–34 VDC supply and features low power consumption.

Two product variants are available: ARM-TL-1 “Low Power”/ ARM-TH-1 “High Power”

Key Features

- Modbus RTU communication for remote adjustment of parameters and smooth device integration into HVAC installations
- Reverse voltage protection: Protects the device against damage caused by incorrect power supply polarity.
- RGB LED indication for monitoring the device status
- Effortless firmware updates via Modbus RTU communication
- Robust enclosure made of Acrylonitrile Butadiene Styrene (ABS) plastic

Area of Use

- Built for the HVAC industry, can be used both in industrial as well as domestic environments
- Demand-Controlled Ventilation (DCV) and industrial automation

Standards

- Low Voltage Directive 2014/35/EU 
- Electromagnetic Compatibility (EMC) Directive 2014/30/EU
- Commission Delegated Directive (EU) 2015/863 (RoHS 3) of 31 March 2015 amending Annex II to Directive 2011/65/EU of the European Parliament and of the Council as regards the list of restricted substances
- WEEE Directive 2012/19/EU

Warnings and Attention Points

- Avoid mounting the device in locations affected by direct sunlight.
- Turn off the power supply before all servicing and maintenance.
- Applying overvoltage will cause improper operation or failure to the internal circuit.
- Do not short-circuit the terminals or the input and output wiring.
- During operation, the unit must be closed.

Article Codes

Article code	Power type
ARM-TL-1	24 VDC (18 – 34 VDC)
ARM-TH-1	

Technical Specifications

Supply voltage	24 VDC
Maximum current consumption	50 mA
Analogue input	
0 – 10 VDC	(load resistance $\geq 1 \text{ k}\Omega$)
0 – 20 mA	(load resistance $\leq 250 \Omega$)
PWM	(load resistance $\geq 1 \text{ k}\Omega$) frequency = 1kHz - 8kHz, voltage level 3,3V-12V
Operating conditions	
Temperature	-10°C to 50°C
Relative humidity	10% to 90% (non-condensing)
Protection standard	
Enclosure	IP65
Enclosure type	
Material	Acrylonitrile Butadiene Styrene (ABS) plastic
Colour	Grey (RAL 7035)

Connect Devices to SenteraWeb



Via a Sentera Internet Gateway you can connect your installation to the SenteraWeb HVAC cloud and:

- Easily change the parameter settings of the connected devices remotely.
 - Define users and give them access to monitor the installation via a standard web browser.
 - Log data - create diagrams and export logged data.
 - Receive alerts or warnings when measured values exceed alert ranges or when errors occur.
 - Create different regimes for your ventilation system - e.g. day-night regime.
- Please refer to the Modbus Register Map of the product for more details regarding the Modbus registers.

ARM-T

Analogue to relay converter

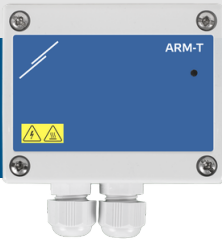

Wiring and Connections

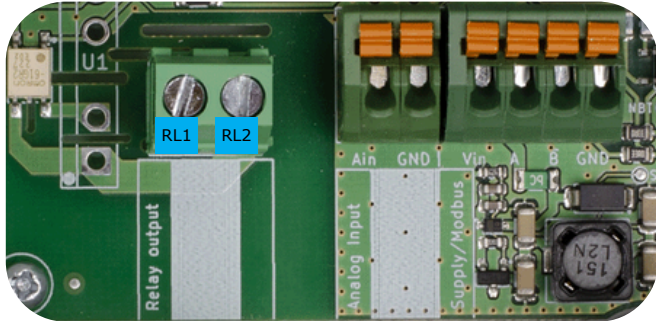

Screw terminal block

RL1	Relay output pin 1	
RL2	Relay output pin 2	
Contact ratings	ARM-TL-1	0-48 VDC 1,3 A
	ARM-TH-1	20-240 VAC 2 A
Cable characteristics	Cable cross section: 1,5-2,5 mm ²	

Spring terminal block

Ain, GND	Analogue input signal
Cable characteristics	Cable cross section: 0,5 mm ²

Spring terminal block

Vin	Supply voltage: 24 VDC
A, /B	Modus RTU (RS485)
GND	Common ground
Cable characteristics	Cat5 or EIB cable

Settings and Indications

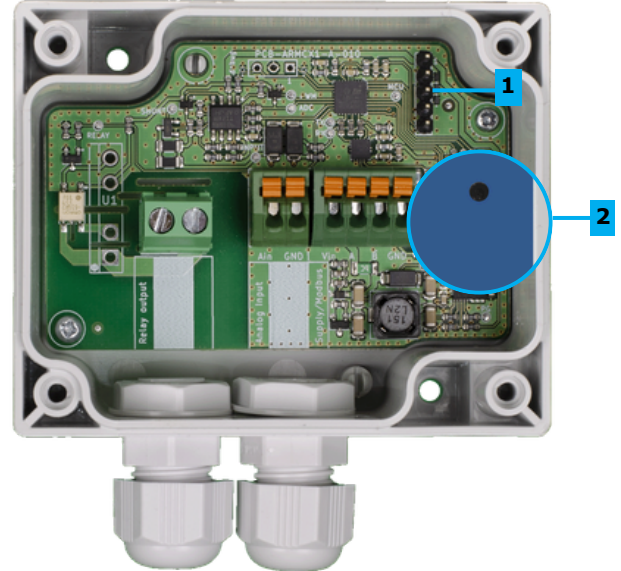

1. PROG header, P1	1 2 3 4 5	Put a jumper onto pins 1 and 2 and wait for at least 5 seconds to reset the Modbus communication parameters
--------------------	-----------	---

On-board LED Indication

2. RGB LED	Continuous white	Relay OFF
	Continuous green	Relay ON
	Red Blinking	Alarm / Error
	Blue Blinking	Bootloader

Packaging

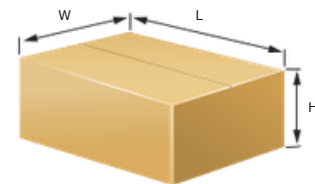

Article code	Packaging	Length [mm]	Width [mm]	Height [mm]	Net weight [kg]	Gross weight [kg]
ARM-TL-1	Unit (1 pc.)	95	85	70	0,17	0,19
	Carton (10 pcs.)	485	175	77	1,7	2,05
	Box (60 pcs.)	580	370	270	10,2	13,3
ARM-TH-1	Unit (1 pc.)	95	85	70	0,25	0,27
	Carton (10 pcs.)	485	175	77	2,58	2,93
	Box (60 pcs.)	580	370	270	15,5	18,5

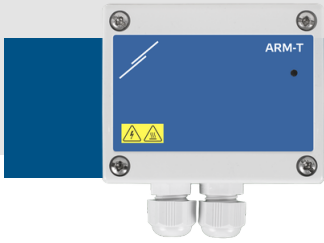

ARM-T

Analogue to relay converter

Fixing and Dimensions

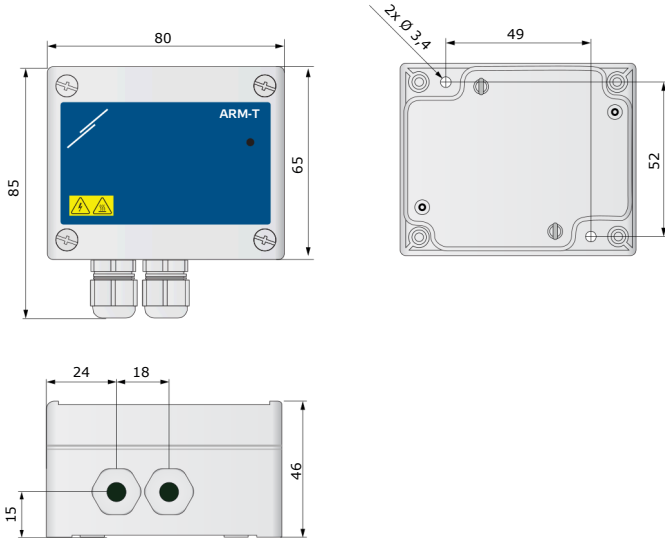

Operational Diagram

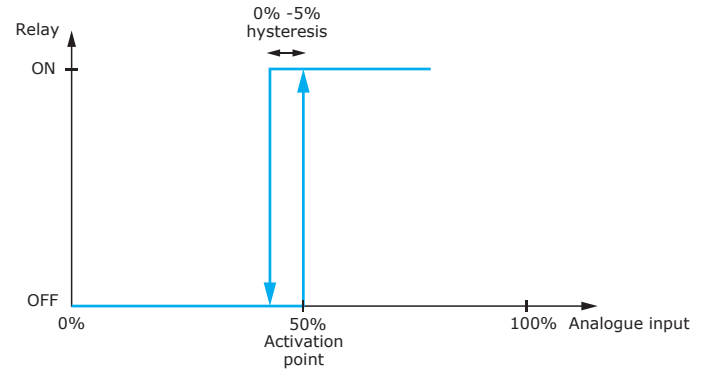

The relay activation threshold is adjustable. By default, it is set to 50 %. When the threshold is set to 50 %, the relay will be activated once the input reaches 50 %. The activation point can be configured via parameter HR34.

Global Trade Item Numbers 14 (GTIN 14)

Article code	Unit	Carton	Box	Pallet
ARM-TL-1	5401003019085	5401003303054	5401003504536	5401003701522
ARM-TH-1	5401003019078	5401003303047	5401003504529	5401003701515

